

Review of Small-Signal Converter-Driven Stability Issues in Power Systems

LE KONG¹ (Graduate Student Member, IEEE), YAOSUO XUE² (Senior Member, IEEE),
LIANG QIAO¹ (Graduate Student Member, IEEE), AND FEI WANG^{1,2} (Fellow, IEEE)

¹Department of Electrical Engineering and Computer Science, The University of Tennessee Knoxville, Knoxville, TN 37996 USA

²Electrical and Electronics System Research Division, Oak Ridge National Laboratory, Oak Ridge, TN 37830 USA

CORRESPONDING AUTHOR: L. KONG (lkong4@vols.utk.edu)

This work was supported in part by the U.S. Department of Energy, Office of Electricity, Advanced Grid Modeling Program, under Contract DE-AC05-00OR22725; in part by the Engineering Research Program of the National Science Foundation and the DOE through NSF under Award EEC1041877, and in part by the CURENT.

ABSTRACT New grid devices based on power electronics technologies are increasingly emerging and introduce two new types of stability issues into power systems, which are different from traditional power system stability phenomena and not well understood from a system perspective. This paper intends to provide the state of the art on this topic with a thorough and detailed review of the converter-driven stability issues in partial or all power electronics-based grids. The underlying and fundamental mechanisms of the converter-driven stability issues are uncovered through different types of root causes, including converter controls, grid strength, loads, and converter operating points. Furthermore, a six-inverter two-area meshed system is constructed as a representative test case to demonstrate these unstable phenomena. Finally, the challenges to cope with the converter-driven stability issues in future power electronics-based grids are identified to elucidate new research trends.

INDEX TERMS Converter-driven stability, harmonic stability, power electronics grids, subsynchronous oscillations.

I. INTRODUCTION

ELECTRIC power systems today are undergoing a transformation from large machine predominant slow electromechanical dynamics to more small or medium-sized semiconductor-induced fast electromagnetic dynamics due to the increasing penetration of power electronics converters (PECs) in the generation, transmission, distribution, and load [1]–[3]. Such an evolution will provide high flexibility, full controllability, sustainability, and improved efficiency for future power grids; however, it also imposes new challenges to power system stability. As indicated by the major results of the work of the IEEE Task Force in [4], in addition to the impacts on classic power system stability issues (rotor angle stability, voltage stability, and frequency stability) [5], two new stability classes, resonance stability and converter-driven stability, are also introduced by the PECs.

For the classical categories of power system stability, many studies have been conducted to analyze the impacts of PECs as listed in Table 1, including impacts on the rotor angle stability [6]–[15], the voltage stability [10], [16], [17], and

the frequency stability [18]–[21]. The interactions between PECs and synchronous machines are also studied, such as the interactions between the synchronous machines and various grid-forming control approaches in [22]. It can be seen that the impacts of PECs on classic power system stability can be either beneficial or detrimental. The detrimental impacts are mainly due to the reduction of system inertia and improper converter control design, while the benefits are mainly due to the faster control dynamics and stronger output regulations of the converters.

For the two new categories of PECs-induced power system stability, the unstable phenomena and possible causes are briefly described in [4]. The resonance stability issues are mainly caused by the effects of flexible alternating current transmission systems or high-voltage direct current transmission systems (HVDC) on torsional aspects (i.e., torsional resonance), and the effects of doubly fed induction generator (DFIG) controls on electrical aspects (i.e., electrical resonance), which encompass the subsynchronous resonance (SSR). The causes of resonance stability have been identified

TABLE 1. Impacts of PECs on classic categories of power system stability.

Classic power system stability	Impacts of PECs (Example Studies and Phenomena)	Positive Causes	Negative Causes
Rotor angle stability	<ul style="list-style-type: none"> ▪ WTGs (U.S. eastern interconnection (EI) in [6, 7] and Midwestern of U.S. interconnection in [8]): <ul style="list-style-type: none"> - Improve stability of nearby SGs and no impacts on SGs located far away during the first swing. - Only slightly engaged in the inter-area oscillations, which might either increase or decrease oscillation damping counting the contributions from SGs. - Increase the oscillation frequency and resonance magnitude. ▪ PVs: <ul style="list-style-type: none"> - Increase system oscillation damping and improve system stability with the proper design of control strategies and parameters [9-12]. - Reduce the interconnected oscillation damping as shown in studies with U.S. EI in [13] and with New-England and New York test systems in [14]. ▪ HVDC: <ul style="list-style-type: none"> - Cause inter-area oscillations according to the operating conditions and control modes in the VSC-HVDC systems as shown in [15], where a 0.55 – 0.65Hz resonance exists in the SGs in the Scottish and the English areas in a 29-bus future Great Britain (GB) network with HVDC connections. 	Converter control features (faster and stronger reactive power support, and strict output power regulations capability)	<div style="border-bottom: 1px solid black; padding-bottom: 5px;">Low inertia</div> <div style="padding-top: 5px;">Improper converter control design</div>
Voltage stability	<ul style="list-style-type: none"> ▪ WTGs: <ul style="list-style-type: none"> - Improve stability margin by utilizing control features of DFIG-WTGs, which is particularly important in largely isolated power systems, e.g., All-island Irish Transmission System AIITS [16]. ▪ PVs: <ul style="list-style-type: none"> - Under the active/reactive power control mode, system voltage stability could be significantly affected, but it will not be affected under active power/voltage control [10, 17]. 	Converter control features	Improper converter control design
Frequency stability	<ul style="list-style-type: none"> ▪ WTGs: <ul style="list-style-type: none"> - Greater frequency oscillations may happen, resulting in different steady-state frequency values if there is generation/load loss as shown in the U.S. EI system study in [18, 19]. - The faster response of VSGs helps with system frequency stability. So, fewer energy storage systems (ESS) are required, e.g., 45% of the original SG-dominated system. But since the system inertia is reduced at the same time, the ESS rating reduction is limited, e.g., to 60% of the original system as shown in a study on AIITS in [20]. ▪ PVs (U.S. EI. in [21]): <ul style="list-style-type: none"> - Decrease non-linearly with the increase of PV penetration level. When PEC penetration increases from 60% to 80%, the system frequency response will drop dramatically, with region frequency dropping much sharper. - By adjusting the voltage/var control modes, the system frequency stability can be improved. 	Converter control features	<div style="border-bottom: 1px solid black; padding-bottom: 5px;">Low inertia</div> <div style="padding-top: 5px;">Improper converter control design</div>

and the solutions have also been proposed accordingly. For example, devices such as static var compensators can be used to damp torsional resonance, and supplemental controllers in DFIG control can help to damp the electrical resonance.

The converter-driven stability issues may exhibit in different forms from classic power system stability issues as indicated by the documented incidents of the unstable operations in power electronics-based grids (PEGs) from field tests, e.g., sub-synchronous oscillations induced between wind turbines generations (WTGs) and series compensated lines in the ERCOT region [23] or harmonic instability issues in photovoltaic (PV) farms [24], [25]. The converter-driven stability is further classified as of slow- or fast- interactions based on the frequencies of the instability [4]. The slow-interaction converter-driven stability refers to the stability issues driven by the slow dynamic interactions between the slow outer control loops of converters and other slow-response components in power systems, typically around system fundamental frequency; while the fast-interaction converter-driven stability (also referred to as harmonic stability [26]) involves the problems caused by fast dynamic interactions between the fast inner control loop of converters and other fast-response components in power systems, typically in the range of hundreds of hertz to several kilohertz. The converter-driven instability

may arise due to many different reasons, such as converter-interfaced generation (CIG) controls, grid strength, converter-interfaced loads (CIL), operating conditions, power transfer limits, and other similar factors [27], [28]. For example, the fast control dynamics of the CIGs may result in rapid frequency changes or transiently distorted voltage/current waveforms, which may lead to the over-reaction of protections fitted to the inverters and cause system tripping [29]. Therefore, it is of significance to fully understand and identify the exact causes for the converter-driven instabilities such that the proper system and converter operation can be designed accordingly.

This paper aims at exploring the underlying fundamental mechanism of converter-driven stability issues in power systems. First, the state of the art on different types of instability issues caused by typical converters in power systems is summarized; and then different stability analysis approaches, such as passivity-based approach or eigenvalue analysis, are applied to systematically analyze the root causes, including the converter-control-induced issues (i.e., control delay, inner and outer control loops, and converter switching actions) and the grid-condition-induced issues (i.e., grid strength, loading conditions, and the system operating conditions). Next, simulation studies are performed using a two-area meshed

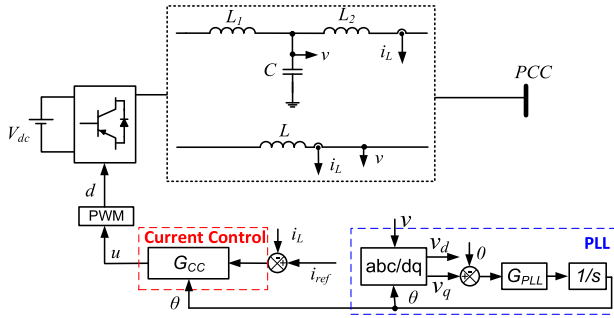

FIGURE 1. Circuit diagram of current-type VSCs [34], [35].

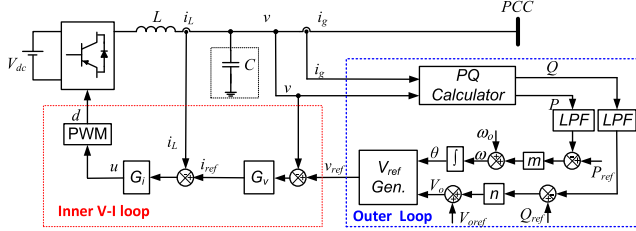

FIGURE 2. Circuit diagram of voltage-type VSCs [36], [37].

network test case. In the end, some open research issues and challenges of the converter-driven stability are discussed accordingly.

II. MECHANISMS OF CONTROL DYNAMICS-INDUCED CONVERTER-DRIVEN STABILITY ISSUES

The dynamics of the entire power grids are determined by the dynamics of each piece of equipment in the system. Therefore, the characteristics of each device in the system need to be investigated. In conventional power grids driven by physical laws, general models for SGs can be obtained in a quasi-static format since the transients of interest are within a narrowband (0.1 Hz to 5 Hz [30]) and the fundamental frequency fluctuations are negligible (due to the large inertia of the rotor [31]). However, in PEGs driven by converter controls, there has not been a generic model yet since PECs highly depend on manufactures and are effective in wide control regions. Plus, the frequency variations cannot be neglected due to the low system inertia. Hence, this section attempts to cover the most used PECs with the root cause analysis for converter-driven stability issues in a wideband control range in power systems.

The converter-interfaced generations and loads in power systems generally use voltage-sourced converters (VSCs), which can be further classified as current-type VSCs as shown in Fig. 1 and voltage-type VSCs as shown in Fig. 2.

The current-type VSCs (also termed as grid-following inverters, GFLs) have been used in many applications, such as PVs, ESSs, and Type-4 WTGs at the generation side or fast-charging stations at the load side. The output current i_L is usually controlled with a proportional-integral (PI) controller in the synchronous frame or with a proportional-resonance controller in the stationery frame. Additionally, a PLL unit

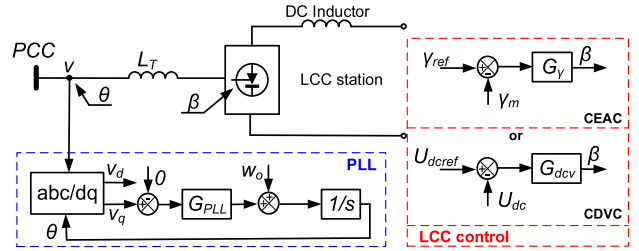

FIGURE 3. Configuration of stations in LCC-HVDC system [38].

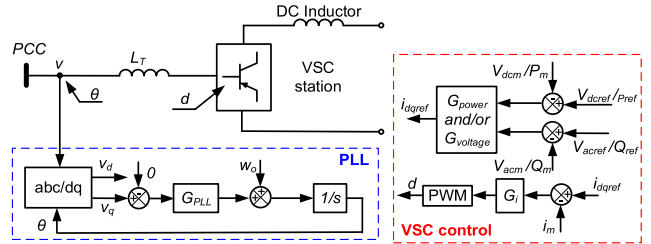

FIGURE 4. Configuration of stations in VSC-HVDC system [33], [39].

is used to obtain the angle θ of the converter terminal voltage in the stationary frame or of measured signals in the synchronous frame. The voltage-type VSCs (also termed as grid-forming inverters, GFMs) are to establish system voltage and frequency autonomously [32]. A typical P - f and a Q - v droop control are adopted to realize power synchronization. The voltage control is to regulate the output voltage, and the current control is to provide damping for the LC resonance and to limit the overcurrent.

Additionally, the converter-interfaced transmissions normally have a rectifier station and an inverter station with either line commutated converter (LCC) as shown in Fig. 3 or VSC as shown in Fig. 4. The LCC-HVDC has been widely used in long-distance transmissions with two common LCC control loops, i.e., constant extinction angle control (CEAC) and constant dc voltage control (CDVC). The VSC-HVDC is also a preferred transmission solution, especially in offshore wind farms with two- or three-level VSC or modular multilevel converters. The rectifier side of VSC-HVDC is normally with PLL control, active power/dc voltage control, and reactive power/ac voltage control loops [33], and the inverter side structure is like current-type VSCs. To limit the scope of this paper, the dc-link dynamics are ignored considering only the dc/ac and ac/dc stages.

The control-induced converter-driven stability (fast- and slow- interaction) issues arising from these four kinds of converters in power systems will be discussed from the following aspects: control delay, inner/outer control, and switching actions. It should be noted that these causes are coupled and may mix to cause converter-driven instabilities.

A. CONVERTER CONTROL DELAY (FAST INTERACTION)

The PECs may cause current harmonics in power systems as shown in Fig. 5 with 830 Hz harmonics in a wind farm [40]. The unstable sources can be identified with the bus

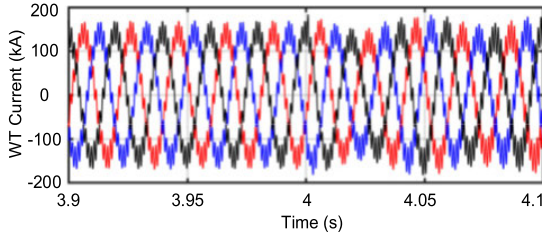

FIGURE 5. Currents of a 400MW WTG injected to power grids [40].

participation factors (PFs) calculated from the multi-input-multi-output transfer function matrix model of the power system and eigenvalue sensitive analysis. Specifically, the converters with larger PFs would introduce harmonic resonances into the system.

The fundamental mechanism behind the phenomena can be further revealed by the passivity-based stability criterion, i.e., for a system described by a rational transfer function $Z(s)$, it is passive if it satisfies: (1) $Z(s)$ is stable and (2) $Re\{Z(j\omega)\} \geq 0 \forall \omega \in (-\infty, \infty)$ or $angle\{Z(s)\} \in [-90^\circ, 90^\circ]$ [41], [42]. Therefore, if a converter impedance is non-passive at some frequencies when connecting to another passive system, instability will possibly happen within these non-passive regions (NPRs). Accordingly, the output admittance of current-type VSCs with LCL filters $Y_{o1}(s)$ is derived, and the converter passivity is examined to identify the root causes. The results show that there is a high frequency (HF) NPR which is caused by the interactions between LC resonance frequency f_r and system control delay T_d . The delay here is assumed to be k times of switching period T_{sw} , which is typically 1.5 and can be reduced to 0.5 with more advanced digital control. The conclusions are: (1) when $f_r < \frac{f_{sw}}{4k}$, the HF-NPR in GFLs with LCL filter is $(f_r, \frac{f_{sw}}{4k})$ as shown in Fig. 6(a); (2) when $f_r = \frac{f_{sw}}{4k}$, there is no HF-NPR, and (3) when $f_r > \frac{f_{sw}}{4k}$, the HF-NPR will be $(\frac{f_{sw}}{4k}, f_r)$, where $f_r = \frac{1}{2\pi\sqrt{L_1C}}$ [41], [43]–[46]. According to the conclusions above, the instability causes for the system in [40] can be dug deeper, where the converter switching frequency f_{sw} is 4 kHz and the control delay is $0.5T_{sw}$. Besides, f_r is 729 Hz which is smaller than 2 kHz. Therefore, the harmonic instability issues would happen within (729 Hz, 2 kHz), which matches with the current waveforms with 830 Hz resonance as shown in Fig. 5.

Following the same approach, the HF-NPR of current-type VSCs with an L filter is identified to be $(\frac{f_{sw}}{4k}, \frac{3f_{sw}}{4k})$ using the output admittance $Y_{o2}(s)$ as shown in Fig. 6(b) [35], [42], [47]. And the HF-NPR of voltage-type VSCs is identified to be $(\frac{f_{sw}}{4k}, \frac{3f_{sw}}{4k})$ with an examination on phase angles of converter output impedance $Z_o(s)$ as shown in Fig. 6(c), which is analogous to the L -filtered current-type VSCs [37], [48], [49]. When the control delay is small enough, e.g., $k = 0.5$, the converter could be passive up to Nyquist frequency $0.5f_{sw}$, which means there would be no harmonic stability issues if connecting the converter to

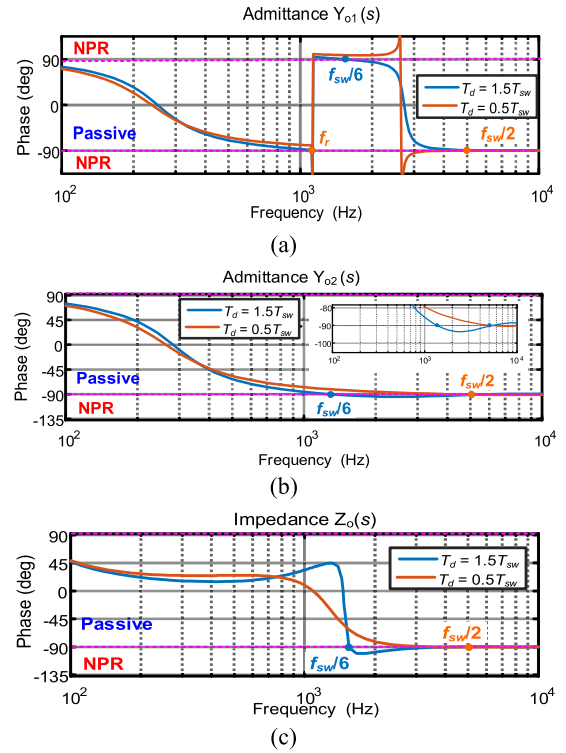

FIGURE 6. Passivity analysis of (a) LCL -filtered current-type VSCs (b) L -filtered current-type VSCs, and (c) voltage-type VSCs.

another passive grid. Plus, if the converter is implemented with silicon-carbide devices instead of silicon devices with a higher switching frequency, the converter passivity could also be guaranteed to a higher absolute value of frequency range and system stability could be improved.

Therefore, to eliminate the control-delay-related converter-driven stability, one direct method is to use advanced controllers to achieve small control delays. Other than that, system stability can also be enhanced by some passivity compensation methods. For example, for current-type VSCs, there are voltage feedforward control [35], [43], [46], lead-lag control [45], active damping [41], [43], [46], passivity-based robust control [44], and adaptive bandpass-filter-based compensation control [50]; for voltage-type VSCs, there are adaptive notch-filter-based compensation control [50], and voltage feedforward control with virtual impedance control block [48], [49]. Note that virtual impedance control may also affect system slow-interaction converter-driven stability. Therefore, the outer loop needs to be refined accordingly.

B. INNER LOOP CONTROL (FAST INTERACTION)

In addition to the control delays as the root cause for system harmonic instability issues, the inner loop control bandwidth will also have some impacts since the control delays typically add negative damping into the alternating current control (ACC) loops of PECs [49], [51]. For example, in a system with multiple paralleled LCL -filtered current-type VSCs, the interactions among the ACC loops with larger

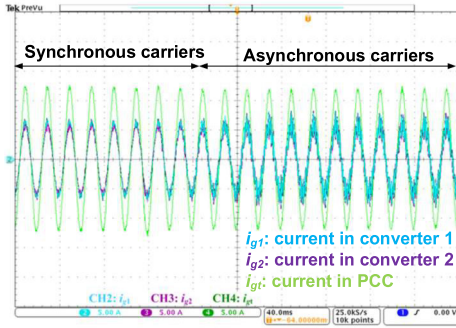

FIGURE 7. Current waveforms with varying carriers [54].

control bandwidth will cause the interactive circulating currents to arise, because the resonance frequency tends to shift to the negative damping region caused by control delays when control bandwidth is increased [52]. A direct solution is to limit the inner current control bandwidth, which may sacrifice the current control dynamics. Apart from this, a multisampling approach can be used [53]. But harmonic instability driven by switching actions would be introduced, causing a distorted grid current with low-frequency aliasing. Hence, a repetitive filter to eliminate the multi-sampling-induced harmonics is also needed.

C. CONVERTER SWITCHING ACTIONS (FAST INTERACTION)

For parallel converters with asynchronous carriers, the pulse-width-modulation (PWM) block generates sideband harmonics which may cause system harmonic instability [54], [55]. Fig. 7 shows the harmonic current waveforms in a system with two-parallel current-type VSCs.

To eliminate the f_{sw} sideband harmonics, a global synchronization of all PWMs through a communication-based central controller is needed. Another way is to add active damping or passive damping into the system to damp the high-frequency oscillations. Plus, the increasing parasitic resistance at a higher frequency due to the skin effect of the output inductor L can provide additional passive damping which is good for system stability. Therefore, the effects of controllers on system stability above Nyquist frequency ($f_{sw}/2$) may be negligible in some cases [56].

D. OUTER LOOP CONTROL (SLOW INTERACTION)

Slow-interaction converter-driven instabilities are also observed in power systems as shown in Fig. 8, which are also called sub-synchronous oscillations (SSO) [57]. The main reason for SSO has been identified as the interactions between the outer control loops of the converters and grid strength (defined by short circuit ratio - SCR).

1) PLL CONTROL

For current-type VSCs, the slow-interaction converter-driven instability is mainly due to the asymmetrical PLL dynamics,

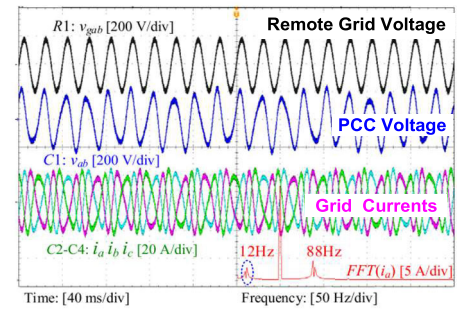

(a)

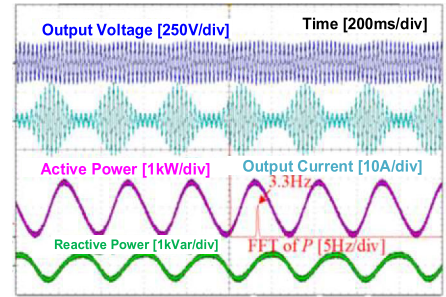

(b)

FIGURE 8. SSO in power systems by (a) current-type VSCs with $SCR = 2$ [61] and (b) voltage-type VSCs with $SCR \approx 10$ [62].

i.e., only regulating q -axis PCC voltage introducing positive feedback into the system [58]–[60]. By examining the closed-loop poles of current-type VSCs, it is found that there is one pair of complex poles ($P_{1,2}$) that have the low-frequency dynamics related to system fundamental frequency sideband oscillations [58]. The root-locus approach is applied to analyze the locations of the poles to study the impact of the PLL (proportional gain K_{pll_P} and integral gain K_{pll_I}) as shown in Fig. 9. For the PLL control parameters, a decrease of proportional gain K_{pll_P} (star line in Fig. 9) and an increase of integral gain K_{pll_I} (circle line) will move the SSO mode-related pole to the unstable region. It is also observed that reduction of the ACC integral gain K_{CC_I} (square line) will have minor impacts on system SSO stability. But the impact of ACC proportional gain K_{CC_P} on system SSO is negligible. Using the impedance-based Nyquist stability analysis approach can draw the same conclusions as discussed in [59, 60]. Additionally, it is found in [63] that the ACC loop may accelerate the equivalent motion of PLL in the first swing, which will worsen system transient stability by enlarging the mismatch between the accelerating and decelerating area in the power angle curve of the analogized synchronous machine model of the current-type VSC.

The PLL control blocks in LCC-HVDC and VSC-HVDC have similar impacts on systems stability. For the LCC-HVDC, a study was conducted based on the small-signal model and eigenvalue analysis to investigate the impacts of PLL and LCC controllers in [38]. First, the PLL bandwidth has significant impacts on system stability. Too large PLL control bandwidth will cause system SSO, especially under weak ac grids. Considering PLL gain stabil-

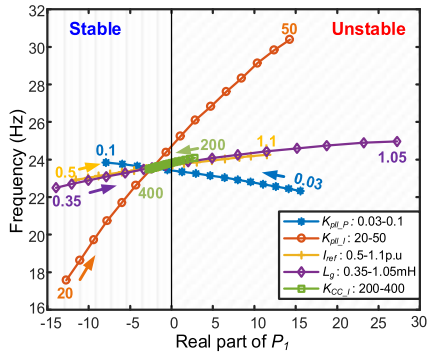

FIGURE 9. Real part of P_1 under different conditions in current-type VSCs [58].

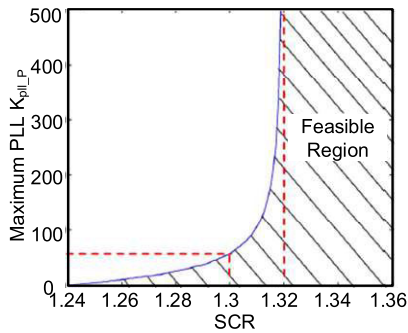

FIGURE 10. System SCR versus K_{pll_P} in VSC-HVDC [33].

ity boundary with different types of LCC controls, the stable region of PLL gain is larger with CDVC than with CEAC. Second, in CEAC controller G_γ , smaller proportional gain K_p and larger integral gain K_I can help improve system stability. While in CDVC controller G_{dcv} , larger K_p and smaller K_I can enhance system stability. Third, there is a close coupling between PLL and LCC control loops, which indicates that the instability caused by larger PLL gain can be eliminated by properly tuning LCC controllers. For the VSC-HVDC, based on the eigenvalue analysis of the corresponding small-signal model, the PLL impacts on system stability can be obtained as shown in Fig. 10. It is seen that when the SCR is larger than 1.32, there will be no stability issues for any value of K_{pll_P} . However, in a system with lower SCR, there will be a maximum K_{pll_P} limitation for system stability. Note that the K_{pll_I} is assumed as c times of K_{pll_P} for simplicity. Another study on a windfarm-connected HVDC transmission is conducted with the impedance-based stability analysis in [39]. It is also found that increasing the voltage loop crossover frequency or reducing the PLL control bandwidth can improve system slow-interaction converter-driven stability.

The PLL-related converter-driven instabilities can be directly solved by tuning PLL control parameters, e.g., reducing PLL bandwidth to limit the effective frequency range of the harmful positive feedback. Another approach is to add active damping, e.g., virtual impedance [34], [64] or feedforward control [61], [65].

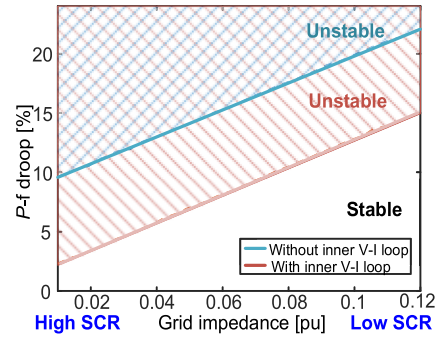

FIGURE 11. Stability boundary of P - f droop vs. grid impedance [66].

2) DROOP CONTROL

In voltage-type VSCs, droop control strategies are normally adopted for power regulation and system synchronization. A complex-value-based output impedance model in the stationary frame is built in [62] to study the impacts of the control loops. It is revealed the interactions of the droop control loops and voltage control loop tend to cause system instability issues. Moreover, a comparative study is conducted in [66] to investigate the differences between multi-loop droop (with inner V - I loop as shown in Fig. 2) and single-loop droop (without inner V - I loop). Fig. 11 shows the results of small-signal stability boundaries under different grid equivalent impedances [66]. It is found that the voltage-loop will make the converter prone to be less damped and lose system stability more easily since the stable region is reduced with inner V - I control. Besides, it is found in [36] that a larger voltage control bandwidth may enhance system SSO stability. Additionally, the Q - v droop impact on system stability is weaker than the p - f droop. Based on these findings, the droop-induced slow-interaction converter-driven instability can be eliminated by tuning the parameters of the more sensitive control blocks, i.e., p - f droop and voltage control.

III. MECHANISM OF GRID CONDITION-INDUCED CONVERTER-DRIVEN STABILITY ISSUES

In addition to various converter control loops, converter-driven stability issues are also dependent on system interactions and operating conditions.

A. GRID STRENGTH (SLOW- AND FAST- INTERACTIONS)

As shown in Fig. 9, Fig. 10, and Fig. 11, the slow-interaction converter-driven stability not only relies on the converter control loops but also depends on the grid strength. In converters with PLL control block, the instabilities would be more likely to be stringent under weak grid conditions. As shown in Fig. 9, an increase of L_g (diamond line), i.e., a weaker grid, will also make P_1 be an RHP pole and cause SSO instability. Note that a weak grid is defined as an ac power system with a low SCR and/or inadequate mechanical inertia by IEEE standard 1204-1997 [67]. It is also worth mentioning that in the LCC-HVDC system, a weak system means an SCR < 2.5. While in VSC-HVDC systems, the SCR for

“weak” or “strong” system boundary is suggested to be 1.3-1.6 as implied by Fig. 10 [33]. However, in converters with droop control, the smaller the grid-impedance is, the smaller the allowed maximum p - f droop gain would be as shown in Fig. 11. That means the SSO instability tends to happen in a strong grid under the same droop gains in voltage-type VSCs, which coincides with results in [36], [62].

The fast-interaction stability may also be affected by the grid strength. For example, if the magnitude of the grid-side impedance intersects with that of converter impedance in the HF-NPR, and the phase difference at the intersection does not meet the stability criterion, then the harmonic instability issues will exhibit [48]. A grid impedance away from the HF-NPR can help eliminate the harmonic instability issues.

B. CONVERTER-INTERFACED LOADS (FAST- AND SLOW-INTERACTION)

The converter-interfaced loads will have very different frequency and voltage characteristics from conventional resistive loads or motor loads. Under some circumstances, the CILs can be considered as current-type VSCs as discussed in Section II-A. It is revealed for simplicity that the CILs exhibit constant power characteristics when the control bandwidth is high enough in some studies [68]–[70]. Therefore, negative incremental impedances will be introduced by the constant power loads (CPLs) across the entire frequency range, and both fast- and slow- interaction converter-driven stability will be affected by this negative damping. Similar findings have been obtained by a microgrids study in [71] with different solutions such as using passive damping, active damping, or more advanced control strategies. One should note that although the CPL assumption is dynamic-wise (i.e., simplifying the load dynamics), it may not always be the worst-case condition for system stability from a control standpoint [72].

C. OPERATING CONDITIONS (FAST- AND SLOW-INTERACTION)

System operating conditions also affect the converter-driven stability, including both fast- and slow- interactions. For example, a theory for harmonics created by resonance in [73] shows that the harmonics may not happen in normal mode, but may suddenly occur and grow before it reaches a certain value if operating conditions change as shown in Fig. 12. The main reason for this phenomenon is that the converter impedance depends on both the operating points and harmonic components. To solve this kind of issue, the focus should be on utilizing passive elements or control strategies to provide more damping to reshape the system impedance.

Moreover, slow-interaction converter-driven stability will also be affected by system operating conditions as shown in Fig. 9 that a larger current I_{ref} (bar line) will induce SSO with higher oscillation frequency. Hence, a proper design of converter impedance characteristics under different operating conditions should be examined to guarantee system stability.

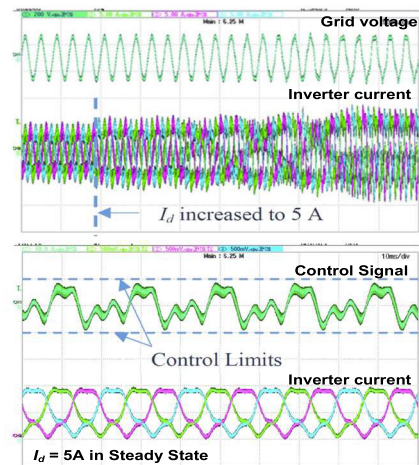

FIGURE 12. Phenomena of harmonics created by resonance in a converter-grid system [73].

IV. CASE STUDIES OF INSTABILITY PHENOMENA IN PEGs

To illustrate the different types of instability phenomena described above, a notional scale-down two-area system interconnected by VSC-HVDC as shown in Fig. 13 was built in MATLAB/Simulink. In each area, a three-bus system is investigated, where G_{x1} and G_{x2} work as voltage-type generators, G_{x3} works as current-type generator/load (x represents Area 1 or Area 2). And G_{x1} provides voltage references for each sub-system. The system is designed to be stable first. Then, based on the review of the possible causes for system instability issues, some typical impact factors are studied by changing the corresponding parameters, such as the inner control, the outer control, or the grid strength. Note that the control and hardware parameters for the stable operations are regarded as benchmark conditions (defined with subscript “BM” in the following text).

Three case studies are conducted in this paper through both time-domain simulations and the Norton admittance matrix (NAM)-based stability analysis with the characteristic loci of the system eigenvalues [74]. The reasons that the NAM-based approach is adopted in these case studies are summarized as follows. First, there are generally two types of modeling approaches for system stability analysis. One is the state-space approach, and the other is the impedance-based approach [26], [75]. The state-space approach is suitable for system low-frequency dynamics modeling and can be used to identify the oscillation modes through eigenvalue analysis. However, if the fast dynamics in the system are considered, the model will become a high-order matrix which might be difficult to compute. Additionally, information of the entire system is required to derive the model. While the impedance-based approach is to analyze the system stability through the interactions between different subsystems, which only needs the terminal characteristics and can be used to identify the impact of each subsystem on system stability. Therefore, an impedance-based approach is adopted in this

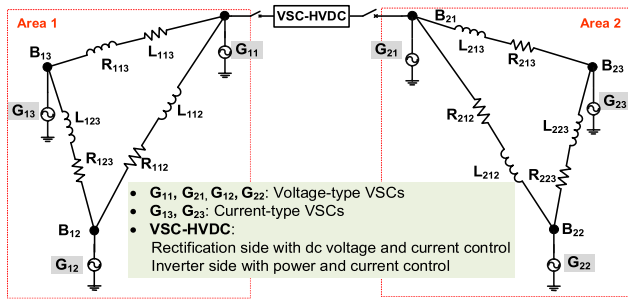

FIGURE 13. Configuration of the test system.

paper. Second, the impedance-based stability criteria can be further categorized into three types, including the Nyquist-based stability analysis, the loop-based stability analysis, and the NAM-based stability analysis [74]. The Nyquist-based approach analyzes system stability through an open-loop model at one partition point. Therefore, the open-loop RHP poles need to be checked first, and the analysis results are sensitive to the partition point. The loop-based approach analyzes the system stability through the closed-loop model, so there is no need to check the open-loop RHP poles and it is insensitive to the system partition point. However, it depends on the circuit operation, and it cannot be used to identify the weak point in the system. The NAM-based approach analyzes the system stability through the closed-loop model with overall system structure, so there is no need to check the open-loop RHP poles. Also, it is insensitive to either the system partition point or circuit operations. It can also be used to identify the weak point and the oscillation frequency in the system by analyzing the characteristic loci of the system return ratio matrix [76], [77]. Therefore, the NAM-based approach is adopted in this paper.

A. CASE I: IMPACT OF INNER CONTROL PARAMETERS

In Case I, Area 1 and Area 2 work independently with VSC-HVDC disconnected, that is no power flowing between Area 1 and Area 2. And the transmission lines in both Area 1 and Area 2 are kept the same as the benchmark system. But the inner control of G_{13} is changed to be 5 times of the benchmark parameters to have a faster inner loop design. Consequently, a 480 Hz harmonic instability issue is observed on B_{13} and the NAM-based stability analysis result also predicts such an oscillation through the characteristic loci as shown in Fig. 14 (420 Hz + 60 Hz).

To eliminate this instability issue, the control bandwidth of the inner loops should be limited as reviewed in Section II. With a slower inner loop, the system can be stabilized as shown in Fig. 15. Note that in the following case studies, only the unstable waveforms will be given considering the page limits.

B. CASE II: IMPACT OF OUTER CONTROL PARAMETERS

First, the PLL control parameters of G_{13} in Area 1 are changed to be $K_{pll_p} = 0.01 * K_{pll_p, BM}$ and $K_{pll_I} = 5 * K_{pll_I, BM}$, and the other parameters are kept the same as the

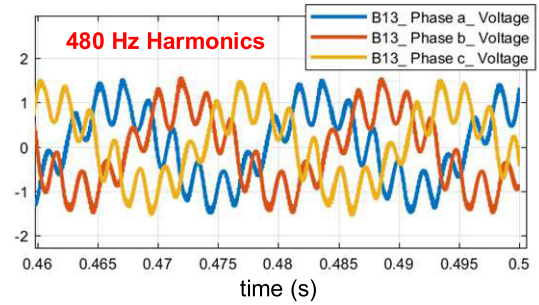

(a)

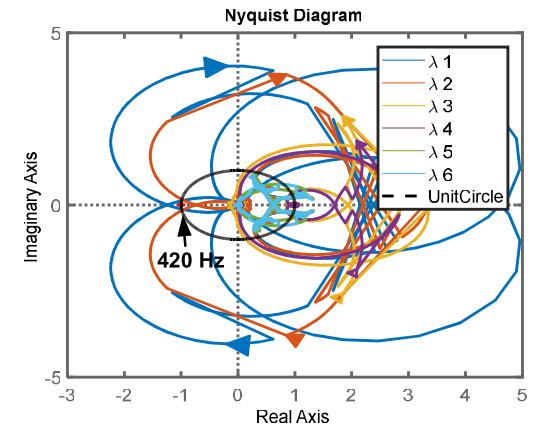

(b)

FIGURE 14. Unstable operation of Area 1 with faster inner loop: (a) phase voltages of B_{13} and (b) NAM-based stability analysis.

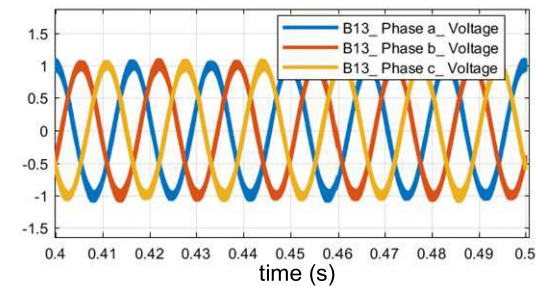

(a)

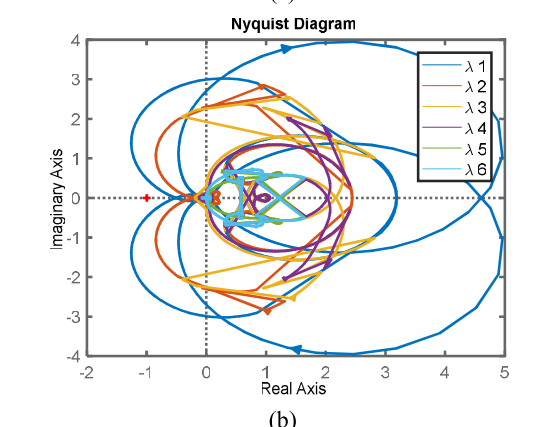

(b)

FIGURE 15. Stable operation of Area 1 with slower inner loop: (a) phase voltages of B_{13} and (b) NAM-based stability analysis.

benchmark system. Also, all the parameters in Area 2 remain the same as the benchmark system. The VSC-HVDC is

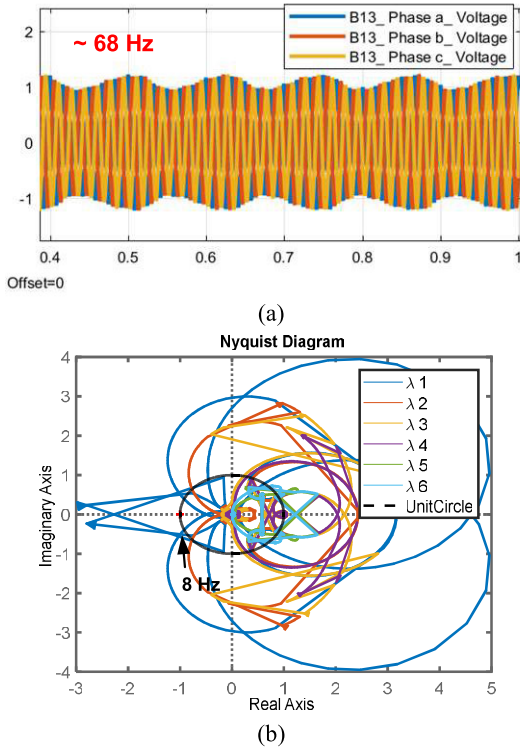

FIGURE 16. Instability issues in Area 1 with improper PLL control of G_{13} : (a) phase voltages of B_{13} and (b) NAM-based stability analysis.

disconnected. It can then be found that due to the improper PLL parameter design, there will be low-frequency oscillations in Area 1 as shown in Fig. 16. The phase voltage of B_{13} shows a 68Hz resonant frequency which matches with the analysis result.

The PLL control blocks in VSC-HVDC will also have a similar impact on system stability as that in current-type VSCs. When there is power flowing from Area 2 to Area 1 through the VSC-HVDC connection, and the parameters in both Area 1 and Area 2 are kept the same as the benchmark system, except the PLL parameters in VSC-HVDC are changed to be $K_{pll_p} = 0.05 * K_{pll_p, BM}$. It can then be observed in Fig. 17 that there will be low-frequency oscillations in both the inverter station and the rectifier station. To remove the slow-interaction instability issues, an increase of K_{pll_p} and a decrease of K_{pll_l} can help as reviewed in Section II.

C. CASE III: IMPACT OF GRID STRENGTH

In Case III, Area 1 and Area 2 work independently with VSC-HVDC disconnected. The transmission line parameters in Area 2 stay unchanged compared with the benchmark system so it is stable, while L_{113} is increased to 5 times of $L_{113, BM}$ and L_{123} changes to 5 times of $L_{123, BM}$ in Area 1 (i.e., weaker connection). It can then be seen from Fig. 18 that a 216 Hz harmonic issue occurs in Area 1. And the impedance-based stability analysis approach also predicts this harmonic resonant frequency. According to the review in

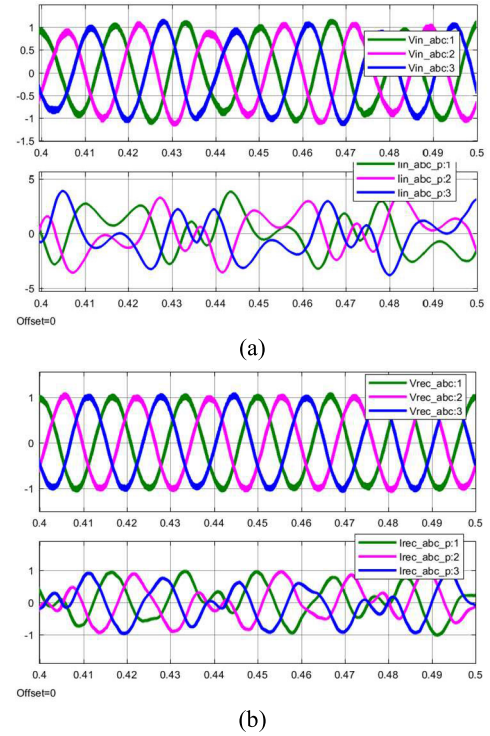

FIGURE 17. Unstable operation of the test system with improper PLL design in VSC-HVDC: (a) inverter station and (b) rectifier station.

Section III, to remove this instability issue, a stronger grid connection is expected.

The other causes reviewed in Section II and Section III, such as the control delay or the loads, can also be studied following the same method used in the case studies above.

V. OPEN RESEARCH ISSUES AND CHALLENGES

With the understanding of the impacts of PECs on power system stability, future all power electronics-based grids can be envisioned. But there are still some challenges going forward.

A. STABILITY ANALYSIS AND IMPROVEMENTS OF LARGE-SCALE PEGs

There have been many papers studying the converter-driven stability issues in small-scale PEGs following the common practice: building system models \rightarrow applying stability analysis approaches \rightarrow developing stability improvement methods \rightarrow conducting simulation/experimental validations [74], [78]. The system model is normally a state-space model or an impedance model, and the corresponding stability analysis is eigenvalue-based analysis or Nyquist criterion. The stability improvement method is usually to improve converter control or to add extra damping. And the analysis results can be simulated by PSCAD, MATLAB, or other software. It is also feasible to build a hardware platform for the small-scale PEGs for further analysis. However, for large-scale PEGs, there is no such study yet. Although people have studied high PE penetrations (e.g., 80%) in the

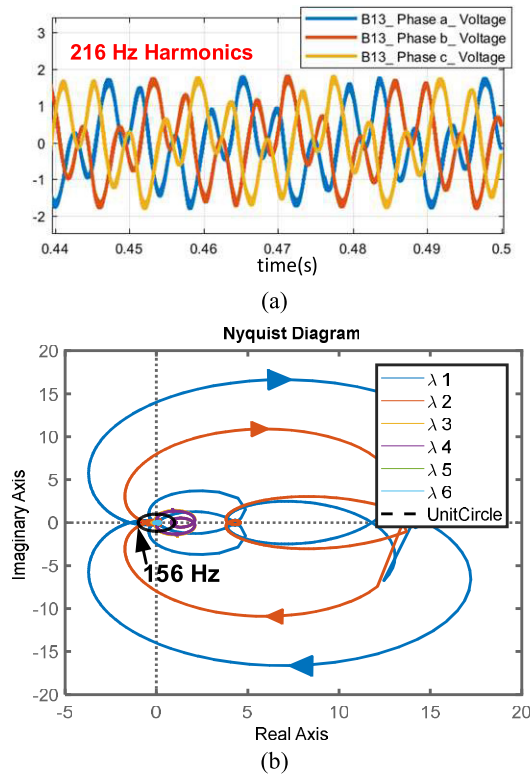

FIGURE 18. Unstable operation of Area 1 in weak grid connection: (a) phase voltages of B₁₃ and (b) NAM-based stability analysis.

large-scale system, the stability analysis mainly focuses on the classic power system stability study in the range of 0.1 Hz – 5 Hz [21]. If directly applying the approaches for the small-scale system to large-scale PEGs, there will be many issues:

(1) A very large state-space matrix or NAM model has to be built first. And when applying the stability analysis approaches, the matrix may not be solvable due to the huge computation burden of the excess matrix dimensions. One may use the Nyquist stability criterion to study the impedance ratio $L_{AC} = Z_{source}/L_{load}$, which is normally a one- or two-order matrix, by simply dividing the system into the source subsystem (Z_{source}) and the load subsystem (L_{load}). However, this approach is sensitive to the partition point and can only reveal the interactive stability of two subsystems at this given point. Therefore, the NAM model is preferred since it can preserve the structure of the entire system and be less sensitive to circuit operations [74], [79].

(2) It is time-consuming to simulate a large-scale PEG on a personal computer. For example, in a case study with 32 Type-III WTGs (48 generators in total) in PSCAD, to investigate 8 seconds system response using average models for the PECs at one operating point, it will take about 20 hours to run the entire simulation with regular Intel®Core (TM) i7-7700 CPU @ 3.60 GHz, not to say using converter switching models. Besides, it is also challenging to build a hardware platform for a large-scale power system.

The solutions for the challenges in studying large-scale PEGs can be considered from either top-down or bottom-up angles [80]. The top-down approach has a global view of the system. First, it is expected to have a generic converter model to cover a wide variety of PECs to simplify the entire system model, which could keep all the important intrinsic characteristics of the PECs and meanwhile simplify the calculation process. Some latest studies have developed generic models for PECs, such as a generic model for wind power plants [81], [82], or the data-driven-based power electronic converter modeling approach [83]. Second, the stability analysis approach should be improved to relax the huge computation burden for a large-scale system, such as the partition-based nodal admittance matrix model for small-signal stability analysis of large-scale PEGs in [77]. Third, for the system simulation, a more powerful computer station with multicores calculated simultaneously can be adopted to speed up the process. While the bottom-up approach starts with the local converter. It is desired that the decentralized control for smart converters [84] can ensure system stability. The passivity-based control can be applied for converter design to enhance system stability. The existing works mainly aim at improving fast-interaction converter-driven stability, but a general solution for slow-interaction stability regarding converter synchronization is still unclear since the low-frequency behavior highly depends on system operating points. Therefore, a decentralized converter control for large-scale system stability under variable working conditions is desired.

B. STABILITY ANALYSIS CONSIDERING SYSTEM NONLINEARITIES

The converter-driven stability analysis for either small-scale or large-scale PEGs above is mainly focused on small-signal stability with system linearization. However, a PEG is inherently a nonlinear system [85], such as large disturbances in systems, power/current limits, or control saturations. To study the system large-signal stability considering all the nonlinearities, a common approach is to use time-domain simulation tools to reflect the system response under some disturbances. Typically, many simulations under different types of disturbances (e.g., faults, generations, or loads dispatch) are needed to characterize system characteristics. There have been some studies focused on large-signal stability analysis on PEGs, such as the converter-level large-signal stability analysis of GFMs or GFLs in grid-connected conditions [86]–[89], or the system-level large-signal analysis on dc microgrids [90]. However, a systematical large-signal stability analysis approach for ac PEGs is still lacking. Therefore, a system-level large-signal stability analysis method for future PEGs considering all the nonlinear effects, especially for large-scale PEGs, should be developed.

VI. CONCLUSION

Power electronics-based grids represent the trend for future electric power systems. New system stability issues like harmonic stability or subsynchronous oscillations, could arise

along with the impacts on classical power system stability. This paper presents a comprehensive analysis of the converter-driven stability issues (fast- and slow- interactions) in power systems with root cause analysis. The results show that the converter control, grid strength, CILs, and system operating conditions all affect system stability. The case studies of a two-area PEG verified these instabilities with illustrative and intuitive explanations. Control and design challenges for future PEGs are also presented.

NOTICE OF COPYRIGHT

This manuscript has been authored by UT-Battelle, LLC, under contract DE-AC05-00OR22725 with the US Department of Energy (DOE). The US government retains and the publisher, by accepting the article for publication, acknowledges that the US government retains a nonexclusive, paid-up, irrevocable, worldwide license to publish or reproduce the published form of this manuscript, or allow others to do so, for US government purposes. DOE will provide public access to these results of federally sponsored research in accordance with the DOE Public Access Plan (<http://energy.gov/downloads/doe-public-access-plan>).

REFERENCES

- [1] L. Kristov, "The bottom-up (R)Evolution of the electric power system: The pathway to the integrated-decentralized system," *IEEE Power Energy Mag.*, vol. 17, no. 2, pp. 42–49, Mar. 2019.
- [2] J. M. Guerrero et al., "Distributed generation: Toward a new energy paradigm," *IEEE Ind. Electron. Mag.*, vol. 4, no. 1, pp. 52–64, Mar. 2010.
- [3] T. Sadamoto, A. Chakraborty, T. Ishizaki, and J.-I. Imura, "Dynamic modeling, stability, and control of power systems with distributed energy resources: Handling faults using two control methods in tandem," *IEEE Control Syst.*, vol. 39, no. 2, pp. 34–65, Apr. 2019.
- [4] N. Hatzigiorgiou et al., "Definition and classification of power system stability revisited & extended," *IEEE Trans. Power Syst.*, vol. 36, no. 4, pp. 3271–3281, Jul. 2021.
- [5] P. Kundur et al., "Definition and classification of power system stability IEEE/CIGRE joint task force on stability terms and definitions," *IEEE Trans. Power Syst.*, vol. 19, no. 2, pp. 1387–1401, Aug. 2004.
- [6] G. Kou, Z. Pan, M. Till, Y. Liu, S. Hadley, and T. King, "Rotor angle stability and inter-area oscillation damping studies on the U.S. eastern interconnection (EI) under high wind conditions," in *Proc. IEEE Power Energy Soc. Gen. Meeting (PESGM)*, Jul. 2016, pp. 1–5.
- [7] Y. Liu, J. R. Gracia, T. J. King, and Y. Liu, "Frequency regulation and oscillation damping contributions of variable-speed wind generators in the U.S. eastern interconnection (EI)," *IEEE Trans. Sustain. Energy*, vol. 6, no. 3, pp. 951–958, Jul. 2015.
- [8] D. Gautam, V. Vittal, and T. Harbour, "Impact of increased penetration of DFIG-based wind turbine generators on transient and small signal stability of power systems," *IEEE Trans. Power Syst.*, vol. 24, no. 3, pp. 1426–1434, Aug. 2009.
- [9] R. Shah, N. Mithulananthan, A. Sode-Yome, and K. Y. Lee, "Impact of large-scale PV penetration on power system oscillatory stability," in *Proc. IEEE PES Gen. Meeting*, Jul. 2010, pp. 1–7.
- [10] B. Tamimi, C. Canizares, and K. Bhattacharya, "Modeling and performance analysis of large solar photo-voltaic generation on voltage stability and inter-area oscillations," in *Proc. IEEE Power Energy Soc. Gen. Meeting*, Jul. 2011, pp. 1–6.
- [11] R. Shah, N. Mithulananthan, and R. C. Bansal, "Damping performance analysis of battery energy storage system, ultracapacitor and shunt capacitor with large-scale photovoltaic plants," *Appl. Energy*, vol. 96, pp. 235–244, Aug. 2012.
- [12] W. Du, H. F. Wang, and R. Dunn, "Power system small-signal oscillation stability as affected by large-scale PV penetration," in *Proc. Int. Conf. Sustain. Power Gener. Supply*, Apr. 2009, pp. 1–6.
- [13] S. You, G. Kou, Y. Liu, X. Zhang, Y. Cui, M. J. Till, W. Yao, and Y. Liu, "Impact of high PV penetration on the inter-area oscillations in the U.S. eastern interconnection," *IEEE Access*, vol. 5, pp. 4361–4369, 2017.
- [14] R. Shah, N. Mithulananthan, and R. Bansal, "Oscillatory stability analysis with high penetrations of large-scale photovoltaic generation," *Energy Convers. Manage.*, vol. 65, pp. 420–429, Jan. 2013.
- [15] S. Asvapoositkul and R. Preece, "Impact of HVDC dynamic modelling on power system small signal stability assessment," *Int. J. Electr. Power Energy Syst.*, vol. 123, Dec. 2020, Art. no. 106327.
- [16] E. Vittal, M. O'Malley, and A. Keane, "A steady-state voltage stability analysis of power systems with high penetrations of wind," *IEEE Trans. Power Syst.*, vol. 25, no. 1, pp. 433–442, Feb. 2010.
- [17] R. Shah, N. Mithulananthan, R. C. Bansal, and V. K. Ramachandramurthy, "A review of key power system stability challenges for large-scale PV integration," *Renew. Sustain. Energy Rev.*, vol. 41, pp. 1423–1436, Jan. 2015.
- [18] M. J. Till, Y. Liu, Y. Liu, M. Patel, and T. King, "Frequency response of the eastern interconnection due to increased wind generation," in *Proc. IEEE PES Gen. Meeting Conf. Expo.*, Jul. 2014, pp. 1–5.
- [19] N. W. Miller, M. Shao, R. D'aquila, S. Pajic, and K. Clark, "Frequency response of the U.S. eastern interconnection under conditions of high wind and solar generation," in *Proc. 7th Annu. IEEE Green Technol. Conf.*, Apr. 2015, pp. 21–28.
- [20] J. Chen, M. Liu, F. Milano, and T. O'Donnell, "100% converter-interfaced generation using virtual synchronous generator control: A case study based on the Irish system," *Electr. Power Syst. Res.*, vol. 187, Oct. 2020, Art. no. 106475.
- [21] S. You et al., "Impact of high PV penetration on U.S. eastern interconnection frequency response," in *Proc. IEEE Power Energy Soc. Gen. Meeting*, Jul. 2017, pp. 1–5.
- [22] A. Tayyebi, D. Groß, A. Anta, F. Kupzog, and F. Dörfler, "Interactions of grid-forming power converters and synchronous machines," 2019, *arXiv:1902.10750*.
- [23] J. Adams, V. A. Pappu, and A. Dixit, "ERCOT experience screening for sub-synchronous control interaction in the vicinity of series capacitor banks," in *Proc. IEEE Power Energy Soc. Gen. Meeting*, Jul. 2012, pp. 1–5.
- [24] C. Li, "Unstable operation of photovoltaic inverter from field experiences," *IEEE Trans. Power Del.*, vol. 33, no. 2, pp. 1013–1015, Apr. 2018.
- [25] J. H. R. Enslin and P. J. M. Heskes, "Harmonic interaction between a large number of distributed power inverters and the distribution network," *IEEE Trans. Power Electron.*, vol. 19, no. 6, pp. 1586–1593, Nov. 2004.
- [26] X. Wang and F. Blaabjerg, "Harmonic stability in power electronic-based power systems: Concept, modeling, and analysis," *IEEE Trans. Smart Grid*, vol. 10, no. 3, pp. 2858–2870, May 2019.
- [27] J. Fang, Y. Tang, H. Li, and F. Blaabjerg, "The role of power electronics in future low inertia power systems," in *Proc. IEEE Int. Power Electron. Appl. Conf. Expo. (PEAC)*, Nov. 2018, pp. 1–6.
- [28] V. N. Sewdien et al., "Effects of increasing power electronics on system stability: Results from MIGRATE questionnaire," in *Proc. Int. Conf. Utility Exhib. Green Energy Sustain. Develop. (ICUE)*, Oct. 2018, pp. 1–9.
- [29] M. Paolone et al., "Fundamentals of power systems modelling in the presence of converter-interfaced generation," *Electr. Power Syst. Res.*, vol. 189, Dec. 2020, Art. no. 106811.
- [30] J. Vega-Herrera, C. Rahmann, F. Valencia, and K. Strunz, "Analysis and application of quasi-static and dynamic phasor calculus for stability assessment of integrated power electric and electronic systems," *IEEE Trans. Power Syst.*, vol. 36, no. 3, pp. 1750–1760, May 2021.
- [31] Y. Ji, W. He, S. Cheng, J. Kurths, and M. Zhan, "Dynamic network characteristics of Power-electronics-based power systems," *Sci. Rep.*, vol. 10, no. 1, p. 9946, Dec. 2020.
- [32] G. Denis, T. Prevost, M.-S. Debry, F. Xavier, X. Guillaud, and A. Menze, "The migrate project: The challenges of operating a transmission grid with inverter-based generation. A grid-forming control improvement with transient current-limiting control," *IET Renew. Power Gener.*, vol. 12, no. 5, pp. 523–529, Apr. 2018.
- [33] J. Z. Zhou, H. Ding, S. Fan, Y. Zhang, and A. M. Gole, "Impact of short-circuit ratio and phase-locked-loop parameters on the small-signal behavior of a VSC-HVDC converter," *IEEE Trans. Power Del.*, vol. 29, no. 5, pp. 2287–2296, Oct. 2014.
- [34] K. M. Alawasa, Y. A.-R. I. Mohamed, and W. Xu, "Active mitigation of subsynchronous interactions between PWM voltage-source converters and power networks," *IEEE Trans. Power Electron.*, vol. 29, no. 1, pp. 121–134, Jan. 2014.

- [35] L. Harnefors, A. G. Yepes, A. Vidal, and J. Doval-Gandoy, "Passivity-based controller design of grid-connected VSCs for prevention of electrical resonance instability," *IEEE Trans. Ind. Electron.*, vol. 62, no. 2, pp. 702–710, Feb. 2015.
- [36] Y. Liao and X. Wang, "Impedance decomposition for design-oriented analysis of grid-forming voltage-source converters," *TechRxiv*, 2020. [Online]. Available: https://www.techrxiv.org/articles/preprint/Impedance_Decomposition_for_Design-Oriented_Analysis_of_Grid-Forming_Voltage-Source_Converters/12855167/1
- [37] Y. Li, Y. Gu, Y. Zhu, A. Junyent-Ferre, X. Xiang, and T. C. Green, "Impedance circuit model of grid-forming inverter: Visualizing control algorithms as circuit elements," *IEEE Trans. Power Electron.*, vol. 36, no. 3, pp. 3377–3395, Mar. 2021.
- [38] A. Zheng, C. Guo, P. Cui, W. Jiang, and C. Zhao, "Comparative study on small-signal stability of LCC-HVDC system with different control strategies at the inverter station," *IEEE Access*, vol. 7, pp. 34946–34953, 2019.
- [39] H. Liu and J. Sun, "Voltage stability and control of offshore wind farms with AC collection and HVDC transmission," *IEEE J. Emerg. Sel. Topics Power Electron.*, vol. 2, no. 4, pp. 1181–1189, Dec. 2014.
- [40] E. Ebrahimzadeh, F. Blaabjerg, X. Wang, and C. L. Bak, "Bus participation factor analysis for harmonic instability in power electronics based power systems," *IEEE Trans. Power Electron.*, vol. 33, no. 12, pp. 10341–10351, Dec. 2018.
- [41] H. Liu, L. Li, Y. Liu, D. Xu, and Q. Gao, "Passivity based damping design for grid-connected converter with improved stability," *IEEE Access*, vol. 7, pp. 185168–185178, 2019.
- [42] F. Hans, W. Schumacher, S.-F. Chou, and X. Wang, "Passivation of current-controlled grid-connected VSCs using passivity indices," *IEEE Trans. Ind. Electron.*, vol. 66, no. 11, pp. 8971–8980, Nov. 2019.
- [43] C. Xie, K. Li, J. Zou, D. Liu, and J. M. Guerrero, "Passivity-based design of grid-side current-controlled LCL-type grid-connected inverters," *IEEE Trans. Power Electron.*, vol. 35, no. 9, pp. 9813–9823, Feb. 2020.
- [44] J. Serrano, S. Cobrecas, E. J. Bueno, and M. Rizo, "Passivity-based robust current control of Grid-connected VSCs," in *Proc. IEEE Appl. Power Electron. Conf. Expo. (APEC)*, Mar. 2020, pp. 745–752.
- [45] H. Yu, H. Tu, and S. Lukic, "A passivity-based decentralized control strategy for current-controlled inverters in AC microgrids," in *Proc. IEEE Appl. Power Electron. Conf. Exposit. (APEC)*, Mar. 2018, pp. 1399–1406.
- [46] A. Akhavan, H. R. Mohammadi, J. C. Vasquez, and J. M. Guerrero, "Passivity-based design of plug-and-play current-controlled grid-connected inverters," *IEEE Trans. Power Electron.*, vol. 35, no. 2, pp. 2135–2150, Feb. 2020.
- [47] L. Harnefors, X. Wang, A. G. Yepes, and F. Blaabjerg, "Passivity-based stability assessment of grid-connected VSCs—An overview," *IEEE J. Emerg. Sel. Topics Power Electron.*, vol. 4, no. 1, pp. 116–125, Mar. 2016.
- [48] Y. Liao, X. Wang, and F. Blaabjerg, "Passivity-based analysis and design of linear voltage controllers for voltage-source converters," *IEEE Open J. Ind. Electron. Soc.*, vol. 1, pp. 114–126, 2020.
- [49] H. Yu, M. A. Awal, H. Tu, Y. Du, S. Lukic, and I. Husain, "Passivity-oriented discrete-time voltage controller design for grid-forming inverters," in *Proc. IEEE Energy Convers. Congr. Expo. (ECCE)*, Sep. 2019, pp. 469–475.
- [50] W. Cao, Y. Ma, and F. Wang, "Adaptive impedance compensation of inverters for stable grid integration based on online resonance detection," in *Proc. IEEE Appl. Power Electron. Conf. Expo. (APEC)*, Mar. 2019, pp. 3151–3158.
- [51] X. Wang, F. Blaabjerg, and P. C. Loh, "Passivity-based stability analysis and damping injection for multiparalleled VSCs with LCL filters," *IEEE Trans. Power Electron.*, vol. 32, no. 11, pp. 8922–8935, Nov. 2017.
- [52] M. Lu, X. Wang, P. C. Loh, and F. Blaabjerg, "Resonance interaction of multiparalleled grid-connected inverters with LCL filter," *IEEE Trans. Power Electron.*, vol. 32, no. 2, pp. 894–899, Feb. 2017.
- [53] S. He, Y. Pan, D. Zhou, X. Wang, and F. Blaabjerg, "Current harmonic analysis of multisampled LCL-type grid-connected inverter," in *Proc. IEEE Energy Convers. Congr. Expo. (ECCE)*, Oct. 2020, pp. 4329–4335.
- [54] D. Yang, X. Wang, and F. Blaabjerg, "Sideband harmonic instability of paralleled inverters with asynchronous carriers," *IEEE Trans. Power Electron.*, vol. 33, no. 6, pp. 4571–4577, Jun. 2018.
- [55] C. Yu *et al.*, "Modeling and resonance analysis of multiparalleled inverters system under asynchronous carriers conditions," *IEEE Trans. Power Electron.*, vol. 32, no. 4, pp. 3192–3205, Apr. 2017.
- [56] L. Harnefors, R. Finger, X. Wang, H. Bai, and F. Blaabjerg, "VSC input-admittance modeling and analysis above the Nyquist frequency for passivity-based stability assessment," *IEEE Trans. Ind. Electron.*, vol. 64, no. 8, pp. 6362–6370, Aug. 2017.
- [57] X. Wang, M. G. Taul, H. Wu, Y. Liao, F. Blaabjerg, and L. Harnefors, "Grid-synchronization stability of converter-based resources—An overview," *IEEE Open J. Ind. Appl.*, vol. 1, pp. 115–134, 2020.
- [58] X. Wu, Z. Du, X. Yuan, G. Wu, and F. Zeng, "Subsynchronous oscillation analysis of grid-connected converter based on MIMO transfer functions," *IEEE Access*, vol. 8, pp. 92089–92097, 2020.
- [59] H. Zhang, L. Harnefors, X. Wang, H. Gong, and J. Hasler, "Stability analysis of grid-connected voltage-source converters using SISO modeling," *IEEE Trans. Power Electron.*, vol. 34, no. 8, pp. 8104–8117, Aug. 2019.
- [60] X. Wang, L. Harnefors, and F. Blaabjerg, "Unified impedance model of grid-connected voltage-source converters," *IEEE Trans. Power Electron.*, vol. 33, no. 2, pp. 1775–1787, Feb. 2018.
- [61] D. Yang, X. Wang, F. Liu, K. Xin, Y. Liu, and F. Blaabjerg, "Symmetrical PLL for SISO impedance modeling and enhanced stability in weak grids," *IEEE Trans. Power Electron.*, vol. 35, no. 2, pp. 1473–1483, Feb. 2020.
- [62] Y. Liao, X. Wang, F. Liu, K. Xin, and Y. Liu, "Sub-synchronous control interaction in grid-forming VSCs with droop control," in *Proc. 4th IEEE Workshop Electron. Grid (eGRID)*, Nov. 2019, pp. 1–6.
- [63] Q. Hu, L. Fu, F. Ma, F. Ji, and Y. Zhang, "Analogized synchronous-generator model of PLL-based VSC and transient synchronizing stability of converter dominated power system," *IEEE Trans. Sustain. Energy*, vol. 12, no. 2, pp. 1174–1185, Apr. 2021.
- [64] J. Fang, X. Li, H. Li, and Y. Tang, "Stability improvement for three-phase grid-connected converters through impedance reshaping in quadrature-axis," *IEEE Trans. Power Electron.*, vol. 33, no. 10, pp. 8365–8375, Oct. 2018.
- [65] X. Zhang, D. Xia, Z. Fu, G. Wang, and D. Xu, "An improved feedforward control method considering PLL dynamics to improve weak grid stability of grid-connected inverters," *IEEE Trans. Ind. Appl.*, vol. 54, no. 5, pp. 5143–5151, Sep/Oct. 2018.
- [66] W. Du *et al.*, "A comparative study of two widely used grid-forming droop controls on microgrid small-signal stability," *IEEE J. Emerg. Sel. Topics Power Electron.*, vol. 8, no. 2, pp. 963–975, Jun. 2020.
- [67] *IEEE Guide for Planning DC Links Terminating at AC Locations Having Low Short-Circuit Capacities*, Standard 1204-1997, IEEE, 1997, pp. 1–216.
- [68] A. Emadi, A. Khaligh, C. H. Rivetta, and G. A. Williamson, "Constant power loads and negative impedance instability in automotive systems: Definition, modeling, stability, and control of power electronic converters and motor drives," *IEEE Trans. Veh. Technol.*, vol. 55, no. 4, pp. 1112–1125, Jul. 2006.
- [69] C. Rivetta, G. A. Williamson, and A. Emadi, "Constant power loads and negative impedance instability in sea and undersea vehicles: Statement of the problem and comprehensive large-signal solution," in *Proc. IEEE Electr. Ship Technol. Symp.*, Jul. 2005, pp. 313–320.
- [70] A. M. Rahimi, A. Khaligh, and A. Emadi, "Design and implementation of an analog constant power load for studying cascaded converters," in *Proc. 32nd Annu. Conf. IEEE Ind. Electron. (IECON)*, Nov. 2006, pp. 1709–1714.
- [71] M. K. AL-Nussairi, R. Bayindir, S. Padmanaban, L. Mihet-Popa, and P. Siano, "Constant power loads (CPL) with microgrids: Problem definition, stability analysis and compensation techniques," *Energies*, vol. 10, no. 10, p. 1656, Oct. 2017.
- [72] M. Cupelli, L. Zhu, and A. Monti, "Why ideal constant power loads are not the worst case condition from a control standpoint," *IEEE Trans. Smart Grid*, vol. 6, no. 6, pp. 2596–2606, Nov. 2015.
- [73] J. Sun, G. Wang, X. Du, and H. Wang, "A theory for harmonics created by resonance in converter-grid systems," *IEEE Trans. Power Electron.*, vol. 34, no. 4, pp. 3025–3029, Apr. 2019.
- [74] C. Zhang, M. Molinas, A. Rygg, and X. Cai, "Impedance-based analysis of interconnected power electronics systems: Impedance network modeling and comparative studies of stability criteria," *IEEE J. Emerg. Sel. Topics Power Electron.*, vol. 8, no. 3, pp. 2520–2533, Sep. 2020.
- [75] M. Amin and M. Molinas, "Small-signal stability assessment of power electronics based power systems: A discussion of impedance- and eigenvalue-based methods," *IEEE Trans. Ind. Appl.*, vol. 53, no. 5, pp. 5014–5030, Sep/Oct. 2017.
- [76] Y. Li *et al.*, "Stability analysis and location optimization method for multiconverter power systems based on nodal admittance matrix," *IEEE J. Emerg. Sel. Topics Power Electron.*, vol. 9, no. 1, pp. 529–538, Feb. 2021.

- [77] L. Qiao, Y. Xue, L. Kong, and F. Wang, "Nodal admittance matrix based area partition method for small-signal stability analysis of large-scale power electronics based power systems," in *Proc. IEEE Appl. Power Electron. Conf. Expo. (APEC)*, Jun. 2021, pp. 687–693.
- [78] W. Cao, Y. Ma, F. Wang, L. M. Tolbert, and Y. Xue, "Low-frequency stability analysis of inverter-based islanded multiple-bus AC microgrids based on terminal characteristics," *IEEE Trans. Smart Grid*, vol. 11, no. 5, pp. 3662–3676, Sep. 2020.
- [79] W. Zhou, R. E. Torres-Olguin, Y. Wang, and Z. Chen, "A gray-box hierarchical oscillatory source identification method of multiple-inverter-fed power systems," *IEEE J. Emerg. Sel. Topics Power Electron.*, vol. 9, no. 3, pp. 3095–3113, Jun. 2021.
- [80] C. K. Tse, M. Huang, X. Zhang, D. Liu, and X. L. Li, "Circuits and systems issues in power electronics penetrated power grid," *IEEE Open J. Circuits Syst.*, vol. 1, pp. 140–156, 2020.
- [81] A. M. Khalil and R. Iravani, "Enhanced generic nonlinear and linearized models of wind power plants," *IEEE Trans. Power Syst.*, vol. 32, no. 5, pp. 3968–3980, Sep. 2017.
- [82] A. Honrubia-Escribano, E. Gómez-Lázaro, J. Fortmann, P. Sørensen, and S. Martin-Martinez, "Generic dynamic wind turbine models for power system stability analysis: A comprehensive review," *Renew. Sustain. Energy Rev.*, vol. 81, no. 2, pp. 1939–1952, 2018.
- [83] N. Guruwacharya et al., "Data-driven power electronic converter modeling for low inertia power system dynamic studies," in *Proc. IEEE Power Energy Soc. Gen. Meeting (PESGM)*, Aug. 2020, pp. 1–5.
- [84] Y. Xue et al., "On a future for smart inverters with integrated system functions," in *Proc. IEEE Int. Symp. Power Electron. Distrib. Gener. Syst. (PEDG)*, Jun. 2018, pp. 1–8.
- [85] R. Darbali-Zamora and E. I. Ortiz-Rivera, "An overview into the effects of nonlinear phenomena in power electronic converters for photovoltaic applications," in *Proc. IEEE 46th Photovoltaic Specialists Conf. (PVSC)*, Jun. 2019, pp. 2908–2915.
- [86] X. Fu et al., "Large-signal stability of grid-forming and grid-following controls in voltage source converter: A comparative study," *IEEE Trans. Power Electron.*, vol. 36, no. 7, pp. 7832–7840, Jul. 2021.
- [87] H. Wu and X. Wang, "Design-oriented transient stability analysis of grid-connected converters with power synchronization control," *IEEE Trans. Ind. Electron.*, vol. 66, no. 8, pp. 6473–6482, Aug. 2019.
- [88] A. Houari, H. Renaudineau, B. Nahid-Mobarakeh, J. Martin, S. Pierfederici, and F. Meibody-Tabar, "Large signal stability analysis and stabilization of converters connected to grid through LCL filters," *IEEE Trans. Ind. Electron.*, vol. 61, no. 12, pp. 6507–6516, Apr. 2014.
- [89] F. Andrade, K. Kampouropoulos, L. Romeral, J. C. Vasquez, and J. M. Guerrero, "Study of large-signal stability of an inverter-based generator using a Lyapunov function," in *Proc. Annu. Conf. IEEE Ind. Electron. Soc. (IECON)*, Oct. 2014, pp. 1840–1846.
- [90] F. Chang, X. Cui, M. Wang, W. Su, and A. Q. Huang, "Large-signal stability criteria in DC power grids with distributed-controlled converters and constant power loads," *IEEE Trans. Smart Grid*, vol. 11, no. 6, pp. 5273–5287, Nov. 2020.



LE KONG (Graduate Student Member, IEEE) received the B.S. degree in electrical engineering and automation from the Nanjing University of Aeronautics and Astronautics, Nanjing, China, in 2014, and the M.S. degree in electrical engineering from the National Taiwan University, Taipei, Taiwan, in 2016. She is currently pursuing the Ph.D. degree with the Department of Electrical Engineering and Computer Science, The University of Tennessee Knoxville.

YAOSUO XUE (Senior Member, IEEE) received the B.Sc. degree in electrical engineering from East China Jiaotong University in 1991 and the M.Sc. degree in electrical engineering from the University of New Brunswick, Canada, in 2004.

From 1991 to 2000, he was an Electrical Engineer-In-Charge at the China's Ministry of Railways. From 2005 to 2006, he worked at Capstone Turbine Corporation. He was a Research Scientist and the Research and Development Manager at Siemens Corporate Research from 2009 to 2015. Currently, he leads the Grid Components and Controls Research Group, Oak Ridge National Laboratory.



LIANG QIAO (Graduate Student Member, IEEE) received the B.S. and M.S. degrees in electrical engineering from Xi'an Jiaotong University, Xi'an, China, in 2015 and 2018, respectively. He is currently pursuing the Ph.D. degree with the Department of Electrical Engineering and Computer Science, The University of Tennessee Knoxville, TN, USA.

His research interests include wide-bandgap devices, advanced gate drivers, and stability of power electronic-based power systems.



FEI (FRED) WANG (Fellow, IEEE) received the B.S. degree from Xi'an Jiaotong University, Xi'an, China, in 1982, and the M.S. and Ph.D. degrees from the University of Southern California, Los Angeles, in 1985 and 1990, respectively, all in electrical engineering.

He was a Research Scientist with the Electric Power Laboratory, University of Southern California, from 1990 to 1992. He joined the GE Power Systems Engineering Department, Schenectady, NY, USA, as an Application Engineer, in 1992. From 1994 to 2000, he was a Senior Product Development Engineer with GE Industrial Systems, Salem, VA, USA. From 2000 to 2001, he was the Manager of the Electronic and Photonic Systems Technology Laboratory, GE Global Research Center, Schenectady, and Shanghai, China. In 2001, he joined the Center for Power Electronics Systems (CPES), Virginia Tech, Blacksburg, VA, USA, as a Research Associate Professor and became an Associate Professor in 2004. From 2003 to 2009, he also served as the CPES Technical Director. Since 2009, he has been with The University of Tennessee Knoxville and Oak Ridge National Laboratory, Knoxville, TN, USA, as a Professor and the Condra Chair of excellence in power electronics. He is a Founding Member and the Technical Director of the multi-university NSF/DOE Engineering Research Center for Ultra-Wide-Area Resilient Electric Energy Transmission Networks (CURENT) led by The University of Tennessee Knoxville. His research interests include power electronics and power systems. He is a fellow of the U.S. National Academy of Inventors.

• • •